

Parts List											
ITEM	QTY	PART NUMBER	DESCRIPTION	MAT	TYP	H	W	L	T	OD	MASS
1	32	90490A033	1/2"-13 HEX NUT								0.044 lbmass
2	68	91083A029	1/4" WASHER								0.004 lbmass
3	32	91083A033	1/2" WASHER								0.018 lbmass
4	68	91251A446	1/4"-28 X 1 1/2" LG SOCKET HEAD CAP SCREW								0.028 lbmass
5	8	95475A746	1/2"-13 THREADED STUD 8" LG								0.057 lbmass
6	1	C1-00	14 X 22 CART 1		ASSEMBLY						
7	2	QS-01	QUARTER SURROUND 1		ASSEMBLY						618.509 lbmass
8	2	QS-02	QUARTER SURROUND 2		ASSEMBLY						618.509 lbmass
9	1	TB-00	MODIFIED TRAPEZE BALANCE		ASSEMBLY						7419.343 lbmass

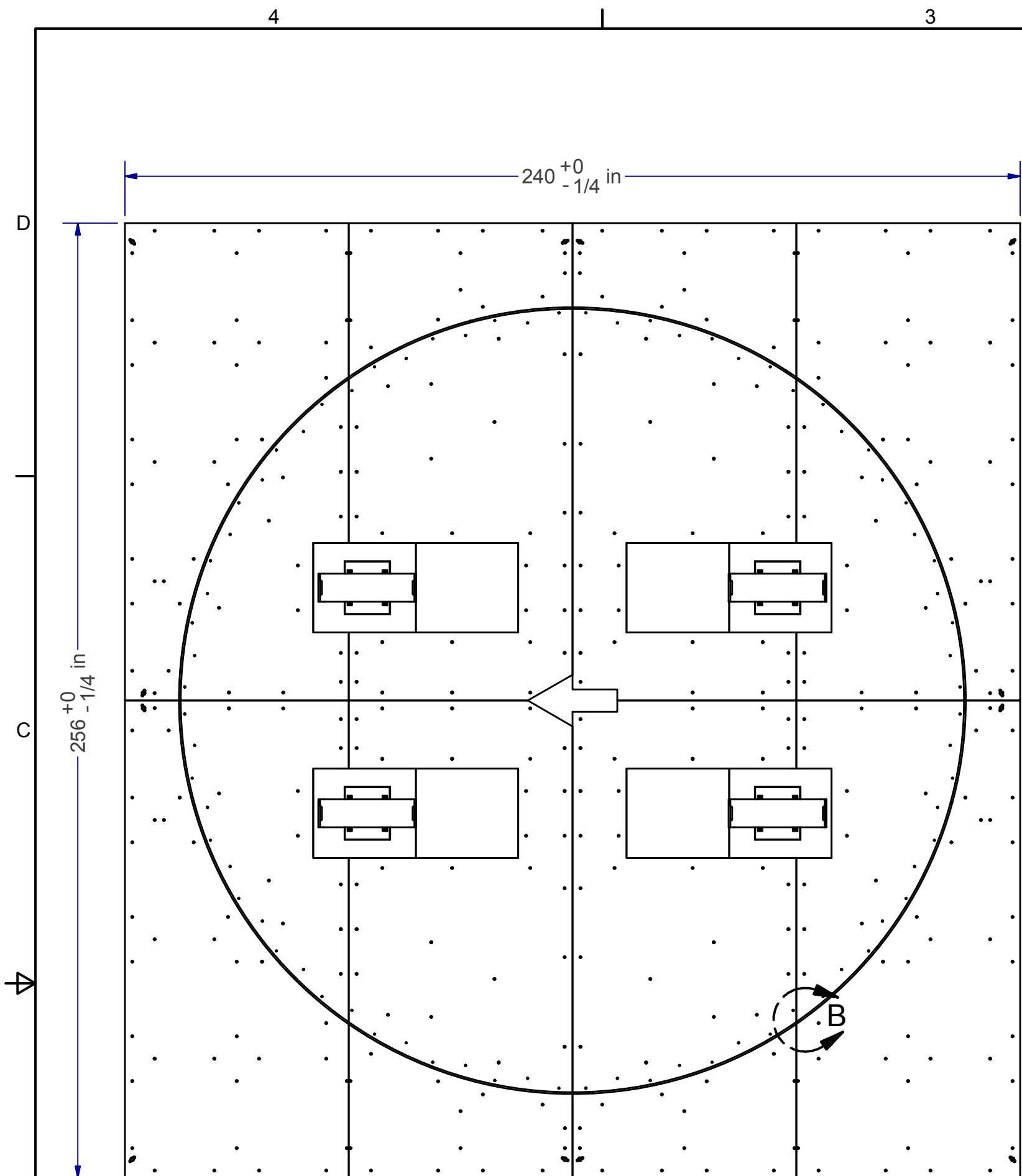

FINAL ASSEMBLY

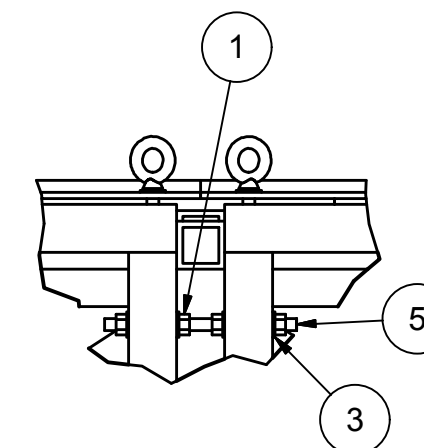
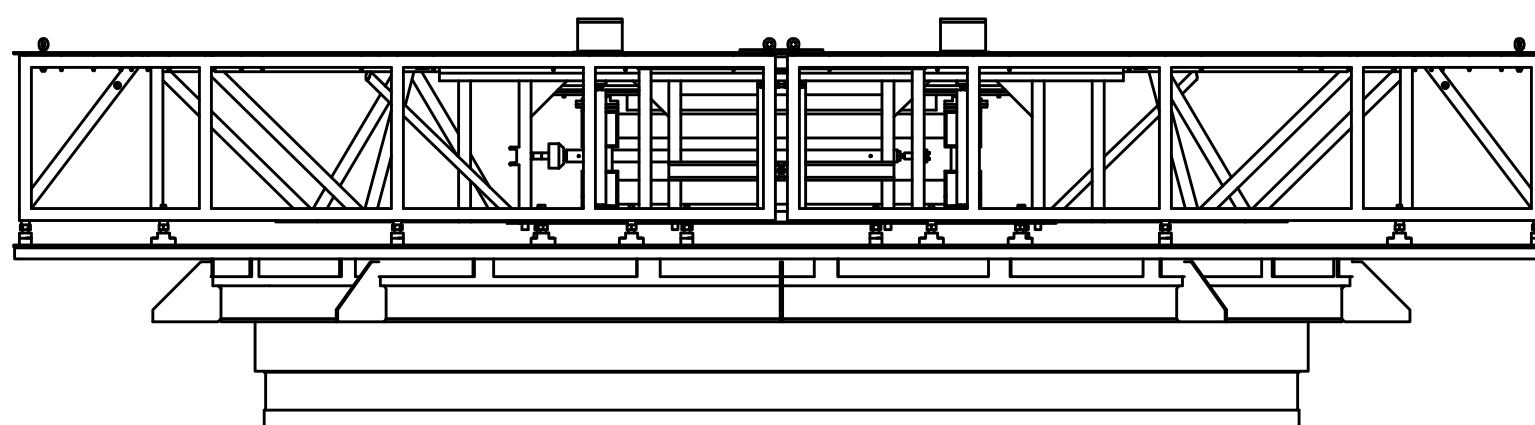
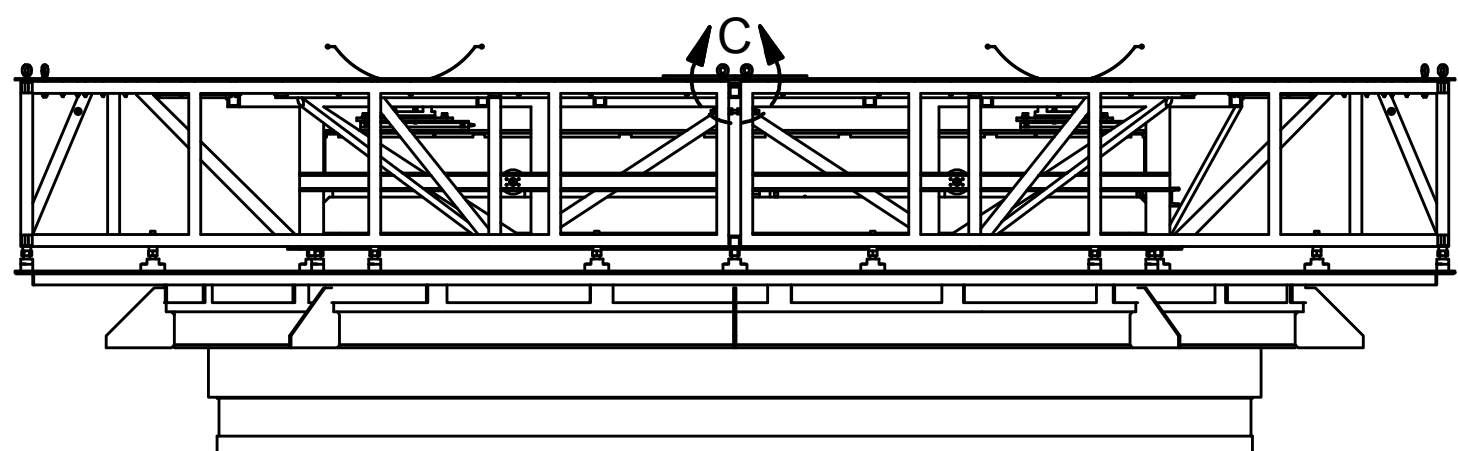
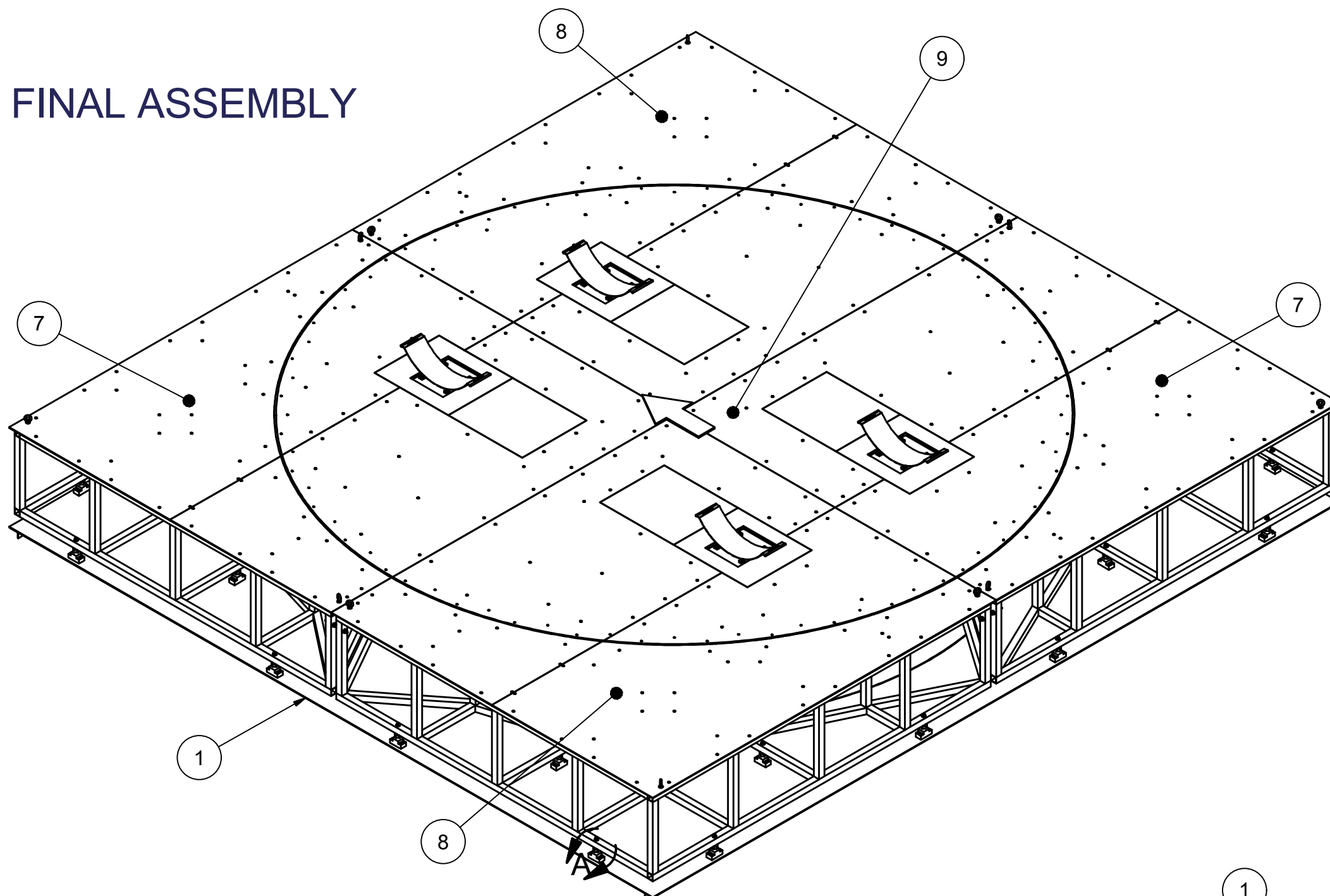

DETAIL C  
SCALE 1 / 8

ONLY 2 BOLTS PER FOOT ARE REQUIRED

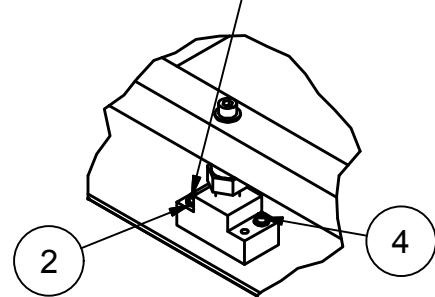

DETAIL A  
SCALE 1 / 8

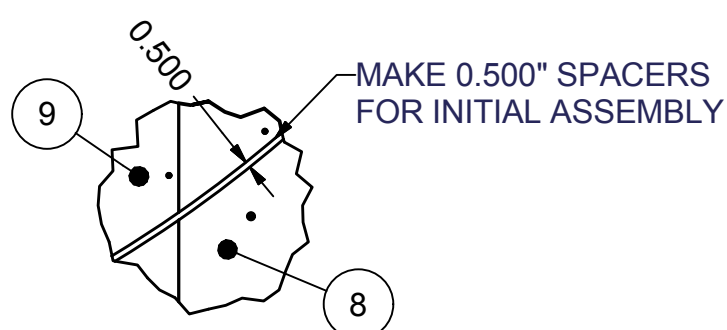

DETAIL B  
SCALE 1 / 16

GENERAL TOLERANCES	
DECIMAL	ANGULAR
X.X" ± 0.5"	XX' ± 1'
X.XX" ± 0.05"	XX.X' ± 0.1'
X.XXX" ± 0.005"	WELDMENTS
X.XXXX" ± 0.0005"	± 1/16"

DRAWN  
JASON MOORE  
ENG. APPROVED BY  
DREW LANDMAN

12/31/2004  
1/6/2005

OLD DOMINION UNIVERSITY  
LANGLEY FULL SCALE TUNNEL

TITLE		
FINAL ASSEMBLY		
SIZE	DWG NO	REV
C	14 X 22 TRAPEZE	
SCALE	SHEET 1 OF 2	
1:32		